

## Homework 1: Suggested Solution

1. Let  $t_{pA}$  and  $t_{pB}$  be the sum of rising and fall propagation delay at point  $A$  and  $B$ .

$$t_{pA, \text{rise}} = t_{p0} \left( 1 + \frac{x+4}{12} \right)$$

$$t_{pA, \text{fall}} = t_{p0} \left( 1 + \frac{x+4}{12} \right)$$

$$t_{pB, \text{rise}} = t_{p0} \left( \frac{x+4}{3} + \frac{16}{x+4} \cdot \frac{2(x+4)}{3x} \right)$$

$$t_{pB, \text{fall}} = t_{p0} \left( \frac{x+4}{3} + \frac{16}{x+4} \cdot \frac{x+4}{12} \right)$$

Total delay  $t_p = t_{pA, \text{rise}} + t_{pA, \text{fall}} + t_{pB, \text{rise}} + t_{pB, \text{fall}}$

$$t_p = t_{p0} \left( 2 + \frac{4}{3} + \frac{5(x+4)}{6} + \frac{32}{3x} \right)$$

$$\frac{\partial t_p}{\partial x} = t_{p0} \left( \frac{5}{6} - \frac{32}{3x^2} \right) = 0$$

$$x = 3.578$$

2. The optimal number of stages =  $\log_{3.6} 720 = 5.136$ . Hence take  $n = 5$  and try integral sizes 1, When  $n = 4$ ,  $f = \sqrt[4]{720} = 5.18$ , try sizes 1, 4, 13, 47, 168

$$t_p = t_{p0} \left( 5 + \frac{4}{1} + \frac{13}{4} + \frac{47}{13} + \frac{168}{47} + \frac{720}{168} \right) = 23.73 t_{p0}$$

While the optimal delay is  $5 \times t_{p0}(1 + 3.6) = 23 t_{p0}$

3. (a) The schematic with sizing

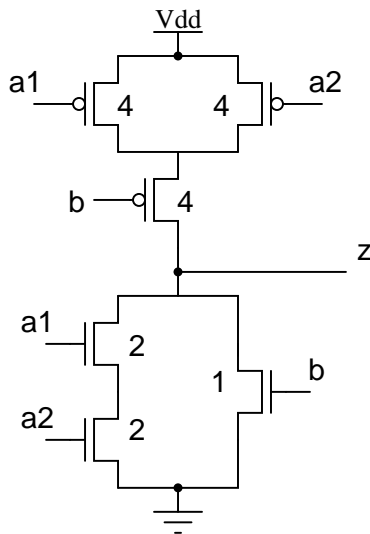

- (c) The stick diagram

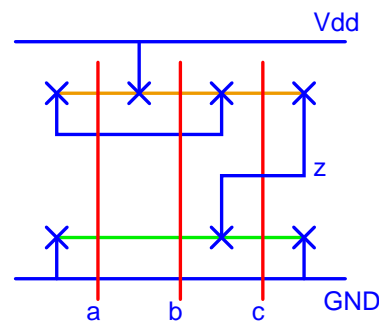

- (b) Delay formula:

$$t_p = t_{p0} \left( \frac{7}{3} + \frac{2f}{\gamma} \right)$$

$$\begin{aligned}
F &= 250 \\
B &= 1 \times \frac{1+2}{1} \times 1 \times 1 = 3 \\
G &= 1 \times \frac{5}{3} \times 1 \times \frac{5}{3} = \frac{25}{9} \\
H &= 250 \times 3 \times \frac{25}{9} = \frac{6250}{3} \\
\hat{h} &= \sqrt[4]{H} = 6.756
\end{aligned}$$

Hence,

$$f_1 = f_b = 6.756, f_a = f_c = 6.756/\frac{5}{3} = 4.054$$

The sizings:

$$\begin{aligned}
s_1 &= \frac{f_1 g_1}{g_a} = \frac{6.756 \times 1}{5/3} = 4.054 \\
s_2 &= \frac{g_1}{g_b} \cdot f_1 \cdot \frac{f_a}{b_a} = 8.723 \\
s_3 &= \frac{g_1}{g_c} \cdot f_1 \cdot \frac{f_a}{b_a} \cdot f_b = 37
\end{aligned}$$

- END -